

2 EACH  
DUMP STRAPS  
EXPANSION RESTRAINT  
(1/4" NYLON ROPE,  
2" FLAT WASHERS)

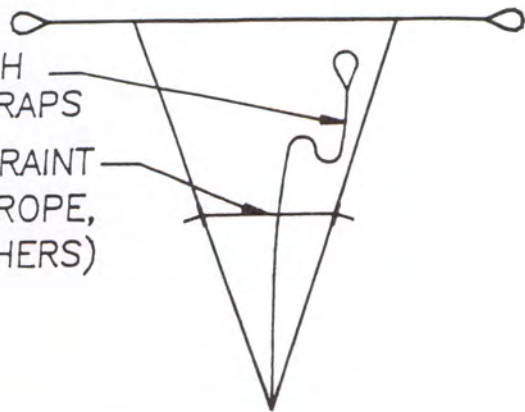

INSTALLATION DETAIL

BAG DETAIL

DUMP STRAP

1" REBAR FOR BAG  
REMOVAL FROM INLET

SILTSACK

DUMP STRAP

DEPTH = D

WIDTH = W

LENGTH = L

LENGTH = \_\_\_\_\_  
WIDTH = \_\_\_\_\_  
DEPTH = \_\_\_\_\_  
QUANTITY = \_\_\_\_\_

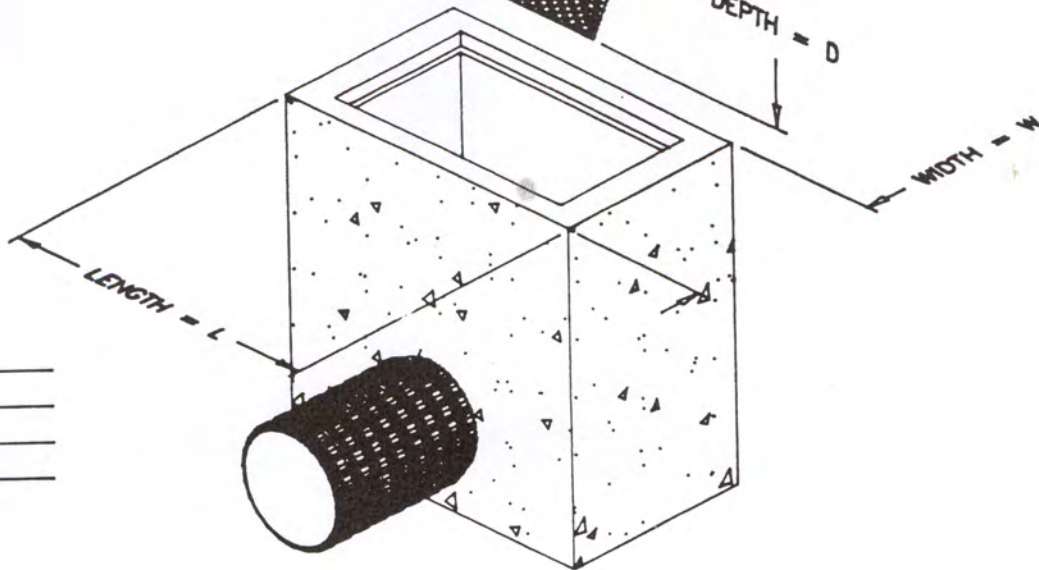

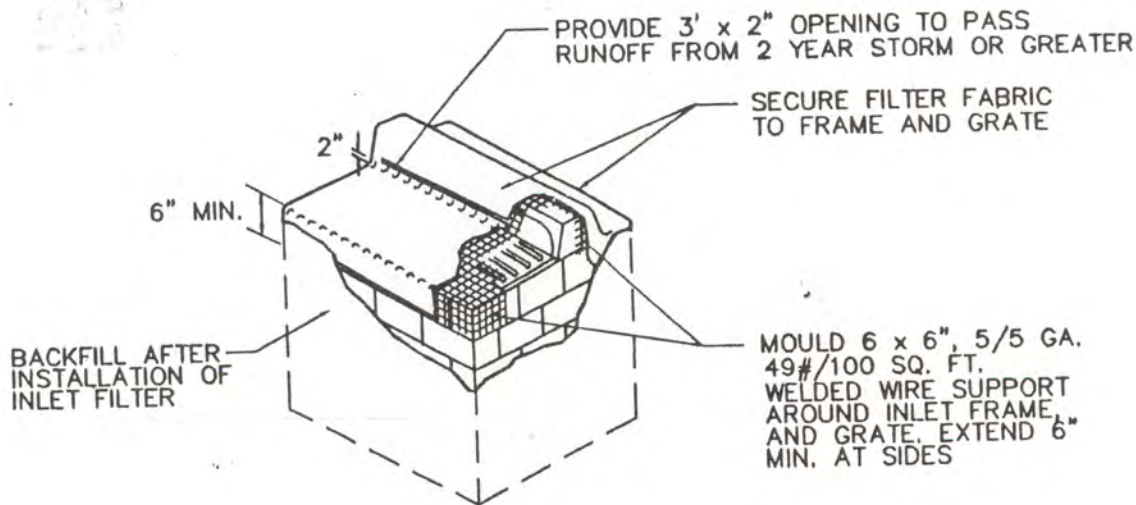

1. CONTRACTOR IS TO CLEAN INLET FILTER AFTER EVERY STORM
2. IF BOTTOM OF ROADWAY BOX IS BELOW TOP OF GRATE, CONSTRUCT OPENINGS IN INLET WALL TO ALLOW WATER TO FLOW IN, COVER OPENINGS WITH WELDED WIRE SUPPORT AND FILTER FABRIC
3. INSPECTION SHALL BE FREQUENT. MAINTENANCE, REPAIR AND REPLACEMENT SHALL BE MADE PROMPTLY, AS NEEDED. THE BARRIER SHALL BE REMOVED WHEN THE AREA DRAINING TOWARDS THE INLET HAS BEEN STABILIZED.

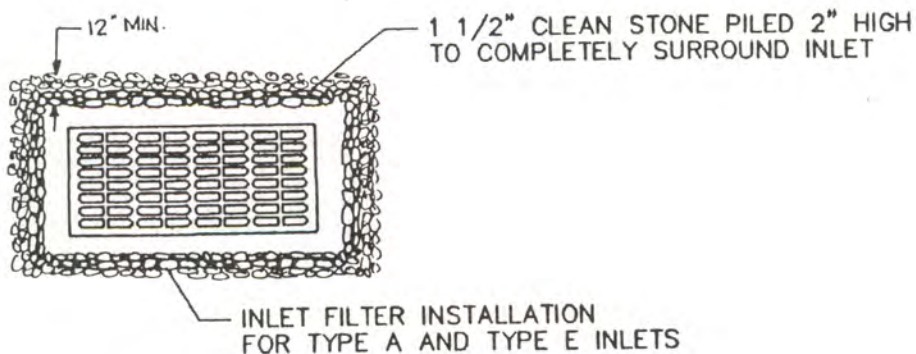

NOTE: TWO TRAFFIC CONES TO BE PLACED ON EACH SIDE OF INLET

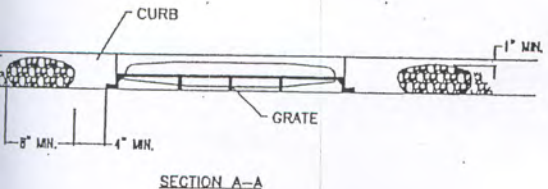

SECTION A-A

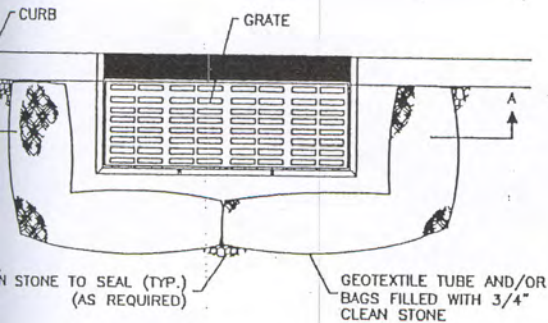

PLAN VIEW

NOTES:

1. GEOTEXTILE TO BE WOVEN POLYPROPYLENE PRODUCT 117F, BY SYNTHETIC INDUSTRIES INC., OR TERRATEX SC, BY WEBTEC INC., OR APPROVED EQUAL.
2. 3/4" CLEAN STONE CORE SHALL BE COMPLETELY CONTAINED WITHIN GEOTEXTILE. SEAMS SHALL BE SEWN OR CLOSED BY SUITABLE MECHANICAL MEANS TO PREVENT LEAKAGE OF STONE.
3. WHERE NO CURB IS PRESENT, BARRIER SHALL COMPLETELY ENIRCLE THE DRAIN INLET.
4. INLET GRATE OPENING IS TO BE KEPT CLEAR OF OBSTRUCTIONS AT ALL TIMES.
5. THE PROTECTION DEVICE WILL BE DESIGNED TO CAPTURE OR FILTER RUNOFF FROM THE 1 YEAR, 24 HOUR STORM EVENT AND SHALL SAFELY CONVEY HIGHER FLOWS DIRECTLY INTO THE STORM SEWER SYSTEM. WHERE SLOPE REQUIRES, AN EARTHEN BERM SHALL BE INSTALLED TO DIRECT STORM FLOW INTO THE INLET, BUT NOT OVER THE CURB.
6. OTHER METHODS THAT ACCOMPLISH THE PURPOSE OF STORM SEWER INLET PROTECTION MAY BE USED IF APPROVED BY THE SOIL CONSERVATION DISTRICT.
7. INSPECTIONS SHALL BE FREQUENT. MAINTENANCE, REPAIR, AND REPLACEMENT SHALL BE MADE PROMPTLY, AS NEEDED. THE BARRIER SHALL BE REMOVED WHEN THE AREA DRAINING TOWARDS THE INLET HAS BEEN STABILIZED.

# INLET FILTER DETAIL

NOT TO SCALE



1 1/2" TO 2 1/2" CLEAN STONE AROUND  
ENTIRE PERIMETER

1" DIAMETER PERFORATIONS

PROVIDE WEIR FOR FLOODING  
RELIEF

2"X6" LUMBER OR EXTERIOR PLYWOOD  
(RIGID FRAME)

INLET FRAME

CURB

2"

NOTE  
SILT TO BE REMOVED FROM AROUND INLET  
PERIODICALLY THROUGHOUT CONSTRUCTION

## TYPE "B" INLET FILTER DETAIL

NOT TO SCALE

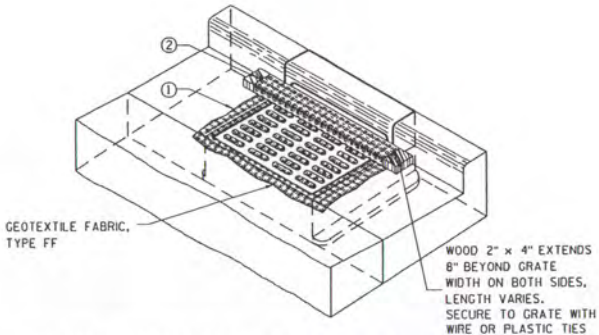

**INLET PROTECTION, TYPE C (WITH CURB BOX)**

## PLAN

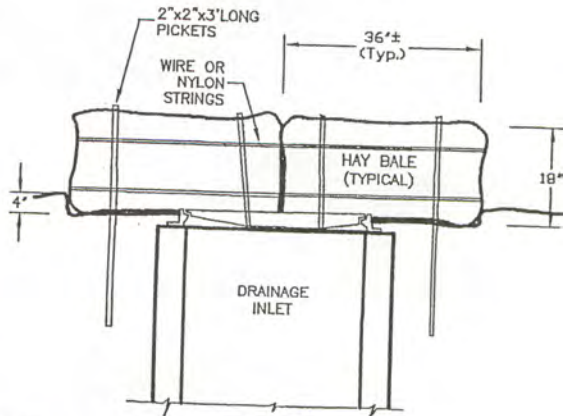
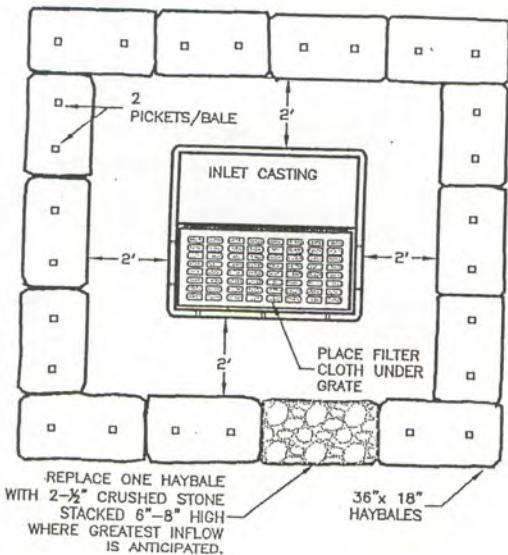

## SECTION

### NOTES:

1. PLACE BALES IN RING AROUND INLET TO FILTER SEDIMENT FROM STORM WATER. RING BARRIER TO REMAIN IN PLACE UNTIL SITE IS STABILIZED OR PAVEMENT IS INSTALLED.
2. ALL BALES SHALL BE EITHER WIRE BOUND OR NYLON STRING TIED.
3. ALL BALES SHALL BE PLACED TIGHTLY ABUTTING ADJACENT BALES.
4. EACH BALE SHALL BE EMBEDDED 4" IN THE GROUND. BALES SHALL BE ANCHORED WITH 2" x 2" x 3" STAKES DRIVEN THROUGH THE BALES A MINIMUM OF 18" INTO THE GROUND. THE FIRST STAKE IN EACH BALE SHALL BE DRIVEN TOWARD THE PLACED BALE TO FORCE BALES TOGETHER.
5. HAYBALES FOR USE ON UNPAVED SURFACES ONLY.
6. INLET MUST SAFELY PASS FLOWS GREATER THAN A 1-YR., 24-HR. STORM EVENT.

# HAY BALE FILTER DETAIL

## UNPAVED SURFACES ONLY

NOT TO SCALE

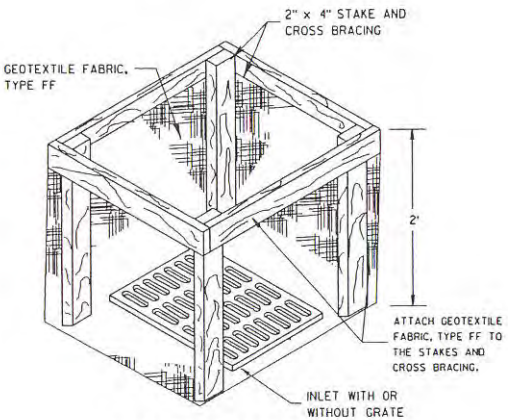
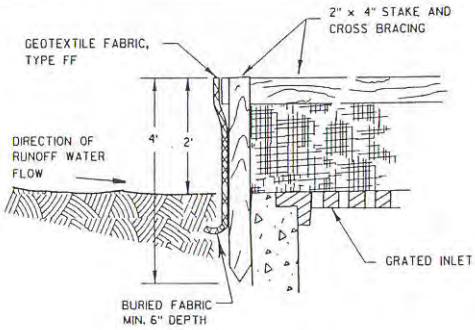

**INLET PROTECTION, TYPE A**

INLET SPECIFICATIONS AS PER THE PLAN  
DIMENSION LENGTH AND WIDTH TO MATCH

FLAP POCKET

③

①  
③  
GEOTEXTILE  
FABRIC, TYPE FF

FRONT, BACK, AND  
BOTTOM TO BE  
MADE FROM SINGLE  
PIECE OF FABRIC.

MINIMUM DOUBLE STITCHED  
SEAMS ALL AROUND SIDE PIECES  
AND ON FLAP POCKETS.

8"  
4"  
12"  
USE REBAR OR STEEL ROD  
FOR REMOVAL  
OR

FOR INLETS WITH CAST  
CURB BOX USE WOOD  
2" X 4", EXTEND 10" BEYOND  
GRATE WIDTH ON BOTH  
SIDES, LENGTH VARIES.  
SECURE TO GRATE WITH  
WIRE OR PLASTIC TIES

4" X 6" OVAL HOLE SHALL BE HEAT  
CUT INTO ALL FOUR SIDE PANELS.

### INLET PROTECTION, TYPE D

(CAN BE INSTALLED IN ANY INLET TYPE WITH  
OR WITHOUT A CURB BOX AS PER NOTE ②)